

Possibilistic networks: *MAP* query and computational analysis

(Preprint version)

Salem BENFERHAT, Karim TABIA
Centre de Recherche en Informatique de Lens (CRIL)
Lens, France
{benferhat,levray,tabia}@cril.fr

Amélie LEVRAY
University of Edinburgh
Edinburgh, Scotland
alevray@inf.ed.ac.uk

Abstract—Possibilistic networks are powerful graphical uncertainty representations based on possibility theory. This paper analyzes the computational complexity of querying min-based and product-based possibilistic networks. It particularly focuses on a very common kind of queries: computing maximum a posteriori explanation (*MAP*). The main result of the paper is to show that the decision problem of answering *MAP* queries in both min-based and product-based possibilistic networks is *NP*-complete. Such computational complexity results represent an advantage of possibilistic networks over probabilistic networks since *MAP* querying is *NP^{PP}*-complete in probabilistic Bayesian networks. We provide the proof based on reduction from the 3SAT decision problem to *MAP* querying possibilistic networks decision problem. As well as reductions that are useful for implementation of *MAP* queries using SAT solvers.

Index Terms—Complexity, Possibilistic networks, *MAP* inference

I. INTRODUCTION

Probabilistic and possibilistic networks [11], [22], [27] are powerful tools to represent and reason with uncertain information. They allow a compact representation of uncertainty distributions using directed acyclic graphs and independence relations. Despite many similarities with probabilistic networks, possibilistic graphical models offer interesting additional advantages especially for modeling and reasoning with qualitative and incomplete uncertainty. As stressed in [19], some possibility theory particularities may offer interesting gains in inference algorithms. For example, in the ordinal possibilistic setting, there may be meaningful gains where the idempotence property of min and max operators benefit to inference algorithms. Also, recent works [9], [16], [23], [30] involves using possibilistic setting applied to web semantics. In this paper, we provide additional benefits for adopting such tools in terms of inferential computational complexity in the context of possibility theory frameworks ([15], [18]). Possibility theory is a natural alternative uncertainty theory particularly appropriate when only the plausibility ordering between events is useful. In fact, there are two main definitions of possibility theories. The first one is called min-based possibility theory. In this setting, the unit interval $[0, 1]$, used for assessing the uncertainty degrees of events, is viewed as an ordinal scale. Hence, only the minimum and maximum operators are used for defining uncertainty measures. This contrasts with the second definition of possibility theory, called

product-based possibility theory, where the unit interval is used in the general sense.

This paper focuses on one of the most important inference task in graphical models which is computing maximum a posteriori explanation (*MAP*). One of the major result of this paper is to show that querying possibilistic networks has a lower complexity than querying probabilistic networks. More precisely, we show that the decision problem associated with answering *MAP* queries in possibilistic networks is *NP*-complete. The proof is provided for both min-based and product-based networks and is built progressively. To show the hardness of the decision problem of *MAP* querying a possibilistic network, we focus on a special type of possibilistic networks called Binary and Boolean possibilistic networks. And we provide a reduction from 3SAT to *MAP* querying a Binary and Boolean possibilistic network. Finally, we provide reductions *MAP* querying a possibilistic network to two known *NP*-complete problems: SAT and weighted MaxSAT decision problems.

The rest of this paper is organized as follows: the first section recalls basic notions on possibilistic frameworks. Then, we discuss motivations and related work. The third section introduces the decision problems of *MAP* query in possibilistic networks and presents an overview of the solution to prove the complexity results of the decision problems considered in this paper. The remaining sections present different polynomial-time reductions used in this paper.

II. BACKGROUND NOTIONS

This section provides a brief refresher on possibility theory (for more details see [18]) and possibilistic networks ([2], [7], [20]). One of the basic elements in possibility theory is the notion of possibility distribution, denoted by π , which is a mapping from the universe of discourse Ω to the unit interval $[0, 1]$. Especially, we consider a finite and discrete universe of discourse. By convention, for a given $\omega \in \Omega$, $\pi(\omega) = 1$ means that ω is fully possible while $\pi(\omega) = 0$ means that it is impossible for ω to be the real world. π is said to be normalized if there is at least an element $\omega \in \Omega$ such that $\pi(\omega) = 1$.

Given a possibility distribution π , one can define a possibility measure, defined for each event $\phi \subseteq \Omega$, by:

$$\Pi(\phi) = \max\{\pi(\omega) : \omega \in \phi\}. \quad (1)$$

It expresses to what extent ϕ is coherent (compatible) with available information represented by π .

There are two interpretations of possibility degrees, either the product-based interpretation of the scale $[0, 1]$ like in probability theory or the min-based interpretation which consider degrees on an ordinal scale. These two interpretations lead to two different ways to deal with possibility degrees. Indeed, updating degrees given a new evidence, namely conditioning, differs whether the interval $[0, 1]$ is just used to rank-order events or not. We call min-based conditioning $|_m$ [18], [21] the operation defined by: given a possibility distribution π , and a new evidence $\phi \subseteq \Omega$ (with $\Pi(\phi) > 0$) the conditional distribution $\pi(\cdot|_m\phi)$ is obtained as follows:

$$\pi(\omega_i|_m\phi) = \begin{cases} 1 & \text{if } \pi(\omega_i) = \Pi(\phi) \text{ and } \omega_i \in \phi; \\ \pi(\omega_i) & \text{if } \pi(\omega_i) < \Pi(\phi) \text{ and } \omega_i \in \phi; \\ 0 & \text{otherwise.} \end{cases} \quad (2)$$

The product-based conditioning, denoted by $|_*$, is, as in the probabilistic setting, defined as follows:

$$\pi(\omega_i|_*\phi) = \begin{cases} \frac{\pi(\omega_i)}{\Pi(\phi)} & \text{if } \omega_i \in \phi; \\ 0 & \text{otherwise.} \end{cases} \quad (3)$$

When there is no ambiguity, we simply write $\pi(\omega|\phi)$ to indifferently refer to $\pi(\omega|_m\phi)$ or $\pi(\omega|_*\phi)$.

The compact representation, in form of a graphical model, associated with a possibility distribution is known as possibilistic networks. As in Bayesian networks, a possibilistic network denoted $\mathcal{PN} = \langle G, \Theta \rangle$ is defined by two components:

- A graphical component G : a directed acyclic graph (DAG) where each node represents a discrete variable (from the set of variables $V = \{X_1, \dots, X_n\}$) and edges encode independence relations between variables.
- A numerical component Θ : a set of local normalized possibility distributions $\Theta_i = \pi_{\mathcal{PN}}(X_i|par(X_i))$ of each node X_i given its parents $par(X_i)$, where the normalized condition is defined by:

$$\forall u_{ij} \in D_{par(X_i)} \max_{x_i \in D_{X_i}} \pi_{\mathcal{PN}}(x_i|u_{ij}) = 1.$$

The semantics associated with a possibilistic network is a joint possibility distribution obtained using a so-called chain rule. As there are two definitions of conditioning, there are also two definitions of chain rule that compute a joint distribution. We denote by \mathcal{PN}_m (respectively \mathcal{PN}_*) a min-based (respectively a product-based) possibilistic network. The possibilistic chain rule for these networks is defined as:

$$\pi_{\mathcal{PN}_{\otimes}}(X_1, \dots, X_n) = \otimes_{i=1, \dots, n} \pi_{\mathcal{PN}_{\otimes}}(X_i|_{\otimes} par(X_i)). \quad (4)$$

where $\otimes = m$ in min-based possibilistic setting and $\otimes = *$ in product-based possibilistic setting.

Example 1. Figure 1 is an example of a possibilistic network on the set of boolean variables $V = \{A, B, C, D\}$.

Again, when there is no ambiguity, we simply write \mathcal{PN} to indifferently refer to \mathcal{PN}_m or \mathcal{PN}_* .

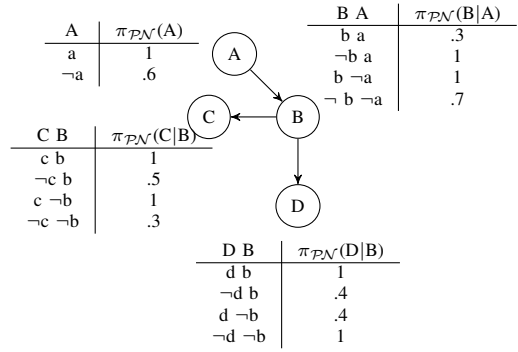

Fig. 1. Example of a possibilistic network \mathcal{PN} over four boolean variables.

III. RELATED WORKS AND MOTIVATIONS

Possibilistic graphical models offer some advantages over probabilistic ones especially for modeling and reasoning with qualitative and incomplete uncertainty. Moreover, possibilistic graphical models also offer nice features regarding practical and computational aspects. This section illustrates two examples of features when it comes to modeling complex problems.

A. Probability underflow/undistinguishable likelihoods

In many real-world problems (eg. forecasting [28], simulation of physical [1] or biological systems [8], [24], etc.) there is need to model a sequential or more generally a dynamic system with many variables over a long period of time. Inference typically consists in computing the likelihood of an outcome or any event of interest given an input. The problem then is that drawing inferences for a long sequence leads inevitably to what is called *probability underflow* problem due to propagating a long series of small probabilities (indeed, the computer representation of numbers does not allow to represent extremely small probabilities and rounds them to zero). As a consequence, two events with relatively different likelihoods will be associated to equal likelihoods. Of course, an alternative and very common approach is to use log likelihood values rather than computing likelihood itself but then over long sequences one can encounter the overflow problem. Possibilistic propagation thanks to the use of idempotent operators will not encounter such a problem.

B. High computational complexity

Inference in probabilistic models is a hard task in the general case. In particular, the decision problem associated with MAP is NP^{PP} -complete (see [12], [14] for more details on complexity issues in Bayesian and credal networks). As said in the introduction, it is important to note that while the complexity results regarding inference in probabilistic networks are well-established [13], there is, to the best of our knowledge, no systematic study of such issues for possibilistic networks (except a study of complexity in possibilistic influence diagrams [20]). Some probabilistic network inference algorithms have already been adapted from the probabilistic setting and seem to show the same complexity. Among the first works on inference

in possibilistic graphical models we mention [17] dealing with inference in hypergraphs. Most of the works are more or less direct adaptations of probabilistic networks inference algorithms. For example, a possibilistic elimination variable algorithm can be found in [5] in the context of possibilistic network classifiers. In [7], a possibilistic counterpart of the well-known Message passing algorithm is proposed. A direct adaptation of the Junction tree algorithm in the possibilistic setting is presented in [6]. Possibilistic networks could also be used to approximate inference models of some imprecise probabilistic models. For instance, in [3], an approach based on probability-possibility transformations is proposed to perform approximate *MAP* inference in credal networks where *MAP* inference is very hard [13]. Clearly, modeling and reasoning with complex problems involving many variables will not be tractable unless strong assumption are made regarding the structure of the network. One of the main results of this paper is to show that querying possibilistic networks has a lower complexity than querying probabilistic ones making the former more appropriate for modeling and reasoning with complex problems.

IV. *MAP* INFERENCE IN POSSIBILISTIC NETWORKS

MAP queries require searching for the most plausible instantiation of query variables Q given an evidence e (an instantiation of a set of variables E). In this paper, we show that the computational complexity of *MAP* querying a possibilistic network is *NP*-complete.

A. Definition of a *MAP* query

Let \mathcal{PN} be a possibilistic network over the set of variables V , $Q \subset V$ be a set of query variables and $E \subset V$ be a set of evidence variables with $Q \cap E = \emptyset$. Then, given an evidence $E = e$, the aim is to compute the most plausible instantiation q of Q given the evidence e . More formally, *MAP* queries aim to compute

$$\operatorname{argmax}_{q \in D_Q} (\Pi_{\mathcal{PN}}(q|e)). \quad (5)$$

Using the maximum property of possibility measures allows us to rewrite Equation (5) as follows:

Proposition 1. *Given a possibilistic network \mathcal{PN} , Q the set of query variables and an evidence e (an instantiation of variables E), we have:*

$$\operatorname{argmax}_{q \in D_Q} (\Pi_{\mathcal{PN}}(q|e)) = \operatorname{argmax}_{q \in D_Q} (\Pi_{\mathcal{PN}}(q \wedge e)),$$

for both min-based and product-based conditioning rule.

B. Decision problem associated with a *MAP* query

We now formally define the decision problem associated with a *MAP* query in min-based possibilistic networks, denoted π_m -**D-MAP**, and in product-based possibilistic networks, denoted π_* -**D-MAP**. They are given in the following definition where we substitute \otimes by m when considering min-based possibilistic setting and by $*$ when considering product-based possibilistic setting:

Definition 1. *By π_{\otimes} -**D-MAP**($\mathcal{PN}_{\otimes}, Q, e, t$) we denote the decision problem associated with *MAP* querying possibilistic networks that we define by:*

Input:

- \mathcal{PN}_{\otimes} : a possibilistic network (min-based or product-based)
- e (evidence): an instantiation of a set of variables E
- Q (query): a set of variables with $Q \cap E = \emptyset$
- t : a real number in $(0, 1]$.

Question: *Is there an instantiation q of non observed variables Q such that $\Pi_{\mathcal{PN}_{\otimes}}(q \wedge e) \geq t$?*

V. OVERVIEW OF THE SOLUTION

We will show that *MAP* inference in possibilistic networks is *NP*-complete. We will provide polynomial-time reductions from some known *NP*-complete problems to our *MAP* decision problems and conversely.

A. Background on satisfiability problems

Let us first recall the basic notions of boolean satisfiability where we only consider formulas that are in conjunctive normal form (this is enough for the purpose of this paper). Let us consider a set of boolean variables $V = \{X_1, \dots, X_n\}$. We denote by x_i ($\neg x_i$ respectively) the positive literal (the negative literal respectively) of variable X_i . A clause C is a disjunction of literals (or a single literal). For instance a clause C would be: $x_1 \vee \neg x_2$. A CNF formula Ψ is a conjunction of clauses (e.g. $C_1 \wedge C_2$). In particular, a 3CNF is a formula in a conjunctive normal form for which each clause is a disjunction of at most 3 literals.

A CNF formula Ψ is said to be satisfiable (or consistent) if there exists an assignment of all the variables (that we also call an interpretation) that renders Ψ true. Now, we define the boolean satisfiability decision problem CNF-SAT (specified for conjunctive normal form formulas), denoted simply by **D-SAT**, as follows:

Definition 2. *By **D-SAT**(Ψ) we denote the decision problem associated to determining if there exists an assignment that satisfies Ψ . It is defined by:*

Input: Ψ a formula in a conjunctive normal form

Question: *Is Ψ satisfiable?*

The **D-3SAT** decision problem is defined as:

Definition 3. *By **D-3SAT**(Ψ) we denote the decision problem defined by:*

Input: Ψ a 3CNF formula

Question: *Is Ψ satisfiable?*

Example 2. *Let us consider the set of variables $V = \{X_1, X_2, X_3, X_4\}$ and the following 3CNF Ψ over V :*

$$(x_1 \vee \neg x_2 \vee x_3) \wedge (\neg x_3 \vee \neg x_2 \vee x_4)$$

Ψ is satisfiable. Indeed the assignment (or interpretation) $\omega = x_1, x_2, \neg x_3, \neg x_4$ satisfies all clauses. Hence, the answer to the decision problem **D-SAT**(Ψ) is "yes".

The last problem that we will refer to in this paper is the weighted MaxSAT problem. This problem generalizes the SAT problem: given a formula with non-negative integer weights on each clause, find an assignment of variables that maximizes the sum of the weights of the satisfied clauses. More precisely, we define its associated decision problem as follows:

Definition 4. By **D-WMaxSAT**(Ψ, k) we denote the decision problem defined by:

Inputs:

- Ψ : a weighted CNF formula over $V = \{X_1, \dots, X_n\}$ simply represented by

$$\Psi = \left\{ \begin{array}{l} (C_1, \alpha_1), \\ (C_2, \alpha_2), \\ \dots \\ (C_m, \alpha_m). \end{array} \right\}$$

where C_i 's are clauses and α_i 's are positive integers.

- k : a positive integer

Question: Is there an instantiation of variables V such that the sum of weights of satisfied clauses in Ψ is greater or equal to k ?

B. Description of the solution

The following section provide the proof of the *NP* completeness of π_m -**D-MAP** and π_* -**D-MAP** decision problems. We then give transformations of *MAP* decision problems in possibilistic networks in order to use SAT solver. The next sections follow these three steps:

- We first show the *NP*-hardness of π_m -**D-MAP** and π_* -**D-MAP**. This is done by providing a reduction from the **D-3SAT** decision problem to both π_m -**D-MAP** and π_* -**D-MAP** decision problems. In this reduction, we use a restricted version of possibilistic networks that only involve boolean variables and binary possibility degrees 0 or 1 (namely, each conditional event is either fully possible or fully impossible). We call this type of networks Boolean and Binary possibilistic networks denoted by B&B possibilistic networks.
- We provide a reduction of the π_m -**D-MAP** decision problem, defined for min-based possibilistic networks, to the **D-SAT** decision problem.
- The last section focuses reducing the π_* -**D-MAP** decision problem, defined for product-based possibilistic networks, to the **D-WMaxSAT** decision problem.

In particular, we highlight the results of the min-based possibilistic setting.

VI. FROM 3SAT TO *MAP* QUERYING OVER B&B POSSIBILISTIC NETWORKS

As described in the overview of the solution, we propose to first reduce the 3SAT decision problem to *MAP* querying Boolean and Binary possibilistic networks.

In this context, we are faced to only consider two kinds of queries: given e an instantiation of evidence variables E , is there an instantiation q of query variables Q such that $\Pi_{\mathcal{P}_{N_{\otimes}}}(q \wedge e) \geq 0$ or such that $\Pi_{\mathcal{P}_{N_{\otimes}}}(q \wedge e) \geq 1$ with $\otimes = m$

for min-based possibilistic setting or $\otimes = *$ for product-based possibilistic setting. The inequality $\Pi_{\mathcal{P}_{N_{\otimes}}}(q \wedge e) \geq 0$ is trivially satisfied since any instantiation q of Q is a solution to the query.

Hence, we will only focus on analyzing the computational complexity of the decision problems π_m -**D-MAP**($\mathcal{P}_{N_{B\&B_m}}, Q, e, 1$) and π_* -**D-MAP**($\mathcal{P}_{N_{B\&B_*}}, Q, e, 1$).

A. Equivalence of the *MAP* decision problem in min-based B&B possibilistic networks and product-based B&B possibilistic networks

Given the definition of a B&B possibilistic network, the following proposition states that the decision problems π_m -**D-MAP**($\mathcal{P}_{N_{B\&B_m}}, Q, e, 1$) and π_* -**D-MAP**($\mathcal{P}_{N_{B\&B_*}}, Q, e, 1$) are equivalent.

Proposition 2. Let e be an instantiation of evidence variables and Q be a subset of query variables. Let $\mathcal{P}_{N_{B\&B_m}}$ and $\mathcal{P}_{N_{B\&B_*}}$ be two B&B possibilistic networks such that $\forall X_i, \forall \mu$ (an instance of parents of X_i , $\pi_{\mathcal{P}_{N_{B\&B_m}}}(X_i|\mu) = \pi_{\mathcal{P}_{N_{B\&B_*}}}(X_i|\mu)$). Then the answer to π_m -**D-MAP**($\mathcal{P}_{N_{B\&B_m}}, Q, e, 1$) is "yes" if and only if the answer to π_* -**D-MAP**($\mathcal{P}_{N_{B\&B_*}}, Q, e, 1$) is "yes".

Proposition 2 means that the answer to a *MAP* query in a B&B possibilistic network does not depend on whether we consider the min-based version of B&B possibilistic networks or the product-based version one. This is due to the fact that operators $*$ and \min applied to possibility degrees 0 and 1 lead to same results. More precisely,

Proposition 3. Let $\mathcal{P}_{N_{B\&B_m}}$ and $\mathcal{P}_{N_{B\&B_*}}$ be two B&B possibilistic networks such that $\forall X_i, \forall \mu$ (an instance of parents of X_i , $\pi_{\mathcal{P}_{N_{B\&B_m}}}(X_i|\mu) = \pi_{\mathcal{P}_{N_{B\&B_*}}}(X_i|\mu)$). Then we have:

$$\forall \omega \in \Omega, \pi_{\mathcal{P}_{N_{B\&B_m}}}(\omega) = \pi_{\mathcal{P}_{N_{B\&B_*}}}(\omega). \quad (6)$$

The proof of Proposition 3 is immediate and follows from the fact that if a and b are either equal to 0 or 1 then $\min(a, b) = a * b$.

B. Reduction from 3SAT problem to **B&B-D-MAP** problem

Now we can tackle the reduction from 3SAT to querying B&B possibilistic networks. Since we showed that *MAP* querying B&B possibilistic networks is the same in min-based or in product-based B&B possibilistic networks, we only consider in this section the decision problem in the min-based possibilistic setting, denoted by **B&B_m-D-MAP**. Since $\Pi_{\mathcal{P}_{N_{\otimes}}}(q \wedge e) \geq 1$ is trivially equivalent to $\Pi_{\mathcal{P}_{N_{\otimes}}}(q \wedge e) = 1$ there is no need to specify the threshold t . Then we get:

Definition 5. By **B&B_m-D-MAP**($\mathcal{P}_{N_{B\&B_m}}, Q, e$) we denote the decision problem associated with *MAP* querying a min-based Boolean and Binary possibilistic network that we define by:

Inputs:

- $\mathcal{P}_{N_{B\&B_m}}$: a min-based binary and boolean possibilistic network over $V = \{X_1, \dots, X_n\}$

- e (evidence): an instantiation of a set of observation variables E
- Q (query): a set of query variables with $Q \cap E = \emptyset$

Question: Is there an instantiation q of variables Q such that $\prod_{\mathcal{PN}_{B\&B_m}}(q \wedge e) = 1$?

We first provide the B&B possibilistic network associated with a 3CNF formula Ψ . This reduction takes inspiration from the probabilistic reduction provided in [10] and used to prove the fact that probabilistic inference in belief networks is NP-hard. More precisely, the B&B possibilistic network associated with a 3CNF is given by the following definition.

Definition 6. Let $\Psi = C_1 \wedge C_2 \wedge \dots \wedge C_m$ be a 3CNF formula. Let $V = \{X_1, \dots, X_n\}$ be the set of propositional variables appearing in Ψ . The B&B possibilistic network associated with Ψ , denoted by \mathcal{PN}_Ψ is defined as follows:

- 1) **Modeling the propositional variables:** For each propositional symbol X_i appearing in Ψ , we create a rooted boolean node variable, also and simply denoted by X_i , in the graph (with two values x_i and $\neg x_i$). Each rooted variable X_i is associated with a local binary possibility distribution defined by: $\pi_{\mathcal{PN}_\Psi}(x_i) = 1$ and $\pi_{\mathcal{PN}_\Psi}(\neg x_i) = 1$.
- 2) **Modeling the satisfaction of a clause C_j :** For each clause C_j of Ψ , we create a conditional node variable, again simply denoted C_j . C_j is a boolean variable, its two values are denoted by c_j and $\neg c_j$. Parents of C_j are the rooted variables X_i that are involved in C_j . Each conditional node variable C_j is associated with a conditional possibility distribution given by: $\forall u_{jk}$ an instance of parents of C_j .

$$\pi_{\mathcal{PN}_\Psi}(c_j|u_{jk}) = \begin{cases} 1, & \text{if } u_{jk} \models C_j, \\ 0, & \text{otherwise.} \end{cases}$$

$$\pi_{\mathcal{PN}_\Psi}(\neg c_j|u_{jk}) = \begin{cases} 0, & \text{if } u_{jk} \models C_j, \\ 1, & \text{otherwise.} \end{cases}$$

where u_{jk} is an instantiation of the parents of C_j , namely the instantiation of variables X_i involved in C_j and $u_k \models C_j$ means that the instantiation u_k satisfies the clause C_j .

- 3) **Modeling the satisfaction of the 3CNF formula Ψ :** Lastly, we add a single boolean node denoted by E_Ψ , which represents the satisfiability of the overall formula Ψ . Its values are denoted by e_Ψ and $\neg e_\Psi$. It has all nodes C_j 's as parents. The conditional possibility distributions associated with E_Ψ are as follow:

$$\pi_{\mathcal{PN}_\Psi}(e_\Psi|C_1 \wedge \dots \wedge C_m) = \begin{cases} 1, & \text{if } \forall C_j, C_j = c_j, \\ 0, & \text{otherwise} \\ & (\exists j \in \{1..m\} \text{ s.t. } C_j = \neg c_j) \end{cases}$$

$$\pi_{\mathcal{PN}_\Psi}(\neg e_\Psi|C_1 \wedge \dots \wedge C_m) = \begin{cases} 0, & \text{if } \forall C_j, C_j = c_j, \\ 1, & \text{otherwise} \end{cases}$$

The reduction (from 3SAT clauses to a B&B possibilistic network) given by Definition 6 is done in polynomial time. Its

space complexity is also polynomial with respect to the size of the formula.

Example 3. Let us consider the 3CNF Ψ of Example 2.

Following Definition 6, the B&B possibilistic network \mathcal{PN}_Ψ , associated with Ψ , consists of three levels of nodes. The first level of nodes represents the set of variables. In this example we have the first level containing the nodes X_1, X_2, X_3 and X_4 as depicted in Figure 2.

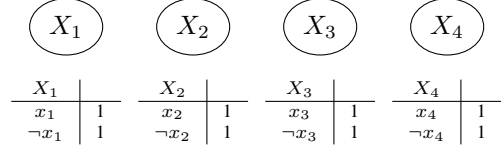

Fig. 2. First level of nodes in \mathcal{PN}_Ψ .

The second level of nodes has 2 nodes C_1 and C_2 with local distributions as illustrated in Figure 3. Note that in local distributions of Figures 3 and 4 we describe by $---$ the remaining instantiations of $\text{par}(C_j)$ and $\text{par}(E_\Psi)$.

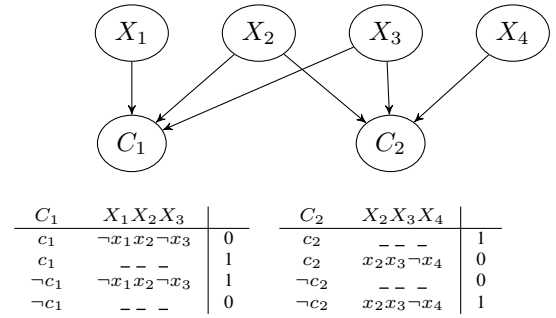

Fig. 3. First two levels of nodes X_i and C_j in \mathcal{PN}_Ψ .

By adding the last node E_Ψ representing the 3CNF formula, we obtain the final binary possibilistic network, given in Figure 4.

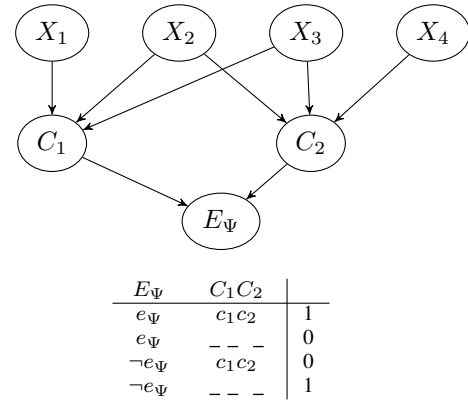

Fig. 4. B&B possibilistic network \mathcal{PN}_Ψ obtained from the 3CNF formula Ψ given in Example 2.

Theorem 1 provides the reduction from the decision problem **D-3SAT**(Ψ) into **B&B_m-D-MAP**(\mathcal{PN}_Ψ, Q, e). The input e is set to e_Ψ while Q is set to the remaining variables in \mathcal{PN}_Ψ (namely, $(\{X_1, \dots, X_n\} \cup \{C_1, \dots, C_m\}) \setminus \{E_\Psi\}$). More formally:

Theorem 1. *Let Ψ be a 3CNF formula. Let \mathcal{PN}_Ψ be the B&B possibilistic network given by Definition 6. Let $V_{\mathcal{PN}_\Psi}$ be the set of variables in \mathcal{PN}_Ψ , namely $\{X_1, \dots, X_n\} \cup \{C_1, \dots, C_m\} \cup \{E_\Psi\}$. Then, **D-3SAT**(Ψ) answer is "yes" if and only if the **B&B_m-D-MAP**($\mathcal{PN}_\Psi, (V_{\mathcal{PN}_\Psi} \setminus \{E_\Psi\}), e_\Psi$) answers "yes" where **D-3SAT** is given in Definition 3 and **B&B_m-D-MAP** is given by Definition 5.*

Proof.

★ Let us assume that the answer to **D-3SAT**(Ψ) is "yes". It means that there exists an interpretation or an instantiation of the variables $\{X_1, \dots, X_n\}$, that we denote ω^* , that satisfies all the clauses in Ψ . If ω is an interpretation and X is a variable then we simply denote by $\omega[X]$ the instance of X present in ω .

Let us construct an interpretation, denoted $\omega_{\mathcal{PN}_\Psi}$, of $V_{\mathcal{PN}_\Psi}$ such that $\omega_{\mathcal{PN}_\Psi} \models e_\Psi$ and $\pi_{\mathcal{PN}_\Psi}(\omega_{\mathcal{PN}_\Psi}) = 1$. For the variable E_Ψ , we let $\omega_{\mathcal{PN}_\Psi}[E_\Psi] = e_\Psi$. For variables $X_i \in \{X_1, \dots, X_n\}$ we let $\omega_{\mathcal{PN}_\Psi}[X_i] = \omega^*[X_i]$. For variables $C_j \in \{C_1, \dots, C_m\}$ we simply let $\omega_{\mathcal{PN}_\Psi}[C_j] = c_j$. Now, let us show that indeed $\pi_{\mathcal{PN}_\Psi}(\omega_{\mathcal{PN}_\Psi}) = 1$.

Recall that for all variables X_i in \mathcal{PN}_Ψ , we have $\pi_{\mathcal{PN}_\Psi}(X_i) = 1$. Since ω^* satisfies all clauses, then for all variables C_j in \mathcal{PN}_Ψ (namely, the set of nodes representing the clauses), we have $\pi_{\mathcal{PN}_\Psi}(c_j | u_{jk}) = 1$ where $\omega^* \models u_{jk}$. Lastly, the variable $E_\Psi = e_\Psi$ when all C_j 's are set to c_j 's respectively have a possibility degree of 1 ($\pi_{\mathcal{PN}_\Psi}(e_\Psi | c_1 \wedge \dots \wedge c_m) = 1$).

Therefore, using the min-based chain rule, we have

$$\begin{aligned} \pi_{\mathcal{PN}_\Psi}(\omega_{\mathcal{PN}_\Psi}) &= \min\{\pi_{\mathcal{PN}_\Psi}(e_\Psi | c_1 \wedge \dots \wedge c_m), \\ &\quad \min_{j=1, \dots, m, \omega_{\mathcal{PN}_\Psi} \models u_{c_j}} \pi_{\mathcal{PN}_\Psi}(c_j | u_{c_j}), \\ &\quad \min_{i=1, \dots, n, \omega_{\mathcal{PN}_\Psi} \models X_i} \pi_{\mathcal{PN}_\Psi}(X_i)\} \\ &= 1 \end{aligned}$$

where u_{c_j} is the instance parents of C_j such that $\omega_{\mathcal{PN}_\Psi} \models u_{c_j}$. Therefore, defining q as the instantiation of Q satisfied by $\omega_{\mathcal{PN}_\Psi}$ we have $\Pi_{\mathcal{PN}_\Psi}(q \wedge e_\Psi) = 1$, hence **B&B_m-D-MAP**($\mathcal{PN}_\Psi, (V_{\mathcal{PN}_\Psi} \setminus \{E_\Psi\}), e_\Psi$) is "yes".

★ Let us assume that the answer to **D-3SAT**(Ψ) is "no". Hence, whatever the considered interpretation $\omega_{\mathcal{PN}_\Psi}$ where $\omega_{\mathcal{PN}_\Psi} \models e_\Psi$ there exists at least C_j such that $\pi_{\mathcal{PN}_\Psi}(c_j | u_{c_j}) = 0$ with $\omega_{\mathcal{PN}_\Psi} \models u_{c_j}$. Hence, $\pi_{\mathcal{PN}_\Psi}(\omega_{\mathcal{PN}_\Psi}) = 0$. So using the min operator of the chain rule, we obtain that $\Pi_{\mathcal{PN}_\Psi}(q \wedge e_\Psi) = 0$ for all instantiation q of Q . Hence, **B&B_m-D-MAP**($\mathcal{PN}_\Psi, (V_{\mathcal{PN}_\Psi} \setminus \{E_\Psi\}), e_\Psi$) is "no". □

This proof can be easily extended to multi-valued variables and non-binary domains. Hence, the following corollary:

Corollary 1. *Let \mathcal{PN}_\otimes be a possibilistic network, Q be a subset of variables, e be an instantiation of evidence variables E (with $E \cap Q = \emptyset$) and let t be a real value in $(0, 1]$ with*

$\otimes = m$ or $\otimes = *$. Then π_{\otimes} -**D-MAP**($\mathcal{PN}_\otimes, Q, e, t$) is NP-complete.

In particular, the **Membership** part of the π_{\otimes} -**D-MAP** is: Given an instance q , it is easy to check if $\Pi(q \wedge e) \geq t$. Indeed, $x = (q, e)$ is a complete instantiation of the network variables, hence the possibility degree $\Pi(q \wedge e)$ is computed in polynomial time (more precisely, in linear time) in the size of the network (number of variables) using the chain rule.

By this reduction we have shown that **MAP** querying possibilistic network is NP-hard. In addition to this proof, we provide converse transformations which are useful for implementation issues of **MAP** queries in possibilistic networks using SAT solvers.

VII. FROM QUERYING min-BASED POSSIBILISTIC NETWORKS TO SAT

In this section, we no longer restrict ourselves to binary possibility distributions. Namely, (conditional) possibility degrees can take any value in the unit interval $[0, 1]$. However, for the sake of simplicity, we still only consider boolean variables. This is not a restriction and the proof can be adapted by encoding a non-boolean variable by a set of boolean variables. We propose to reduce the decision problem π_m -**D-MAP** to the decision problem **D-SAT**.

A. Definition of a CNF formula associated with a min-based possibilistic network

In this subsection, we define the transformation of a min-based possibilistic network \mathcal{PN}_m into a CNF formula, denoted $\Psi_{\mathcal{PN}_m, Q, e, t}$. The following gives the definition of the CNF formula associated with the network \mathcal{PN}_m , the set Q , the evidence e (an instantiation of the variables E) and the real number t in $\Psi_{\mathcal{PN}_m, Q, e, t}$.

Definition 7. *Let \mathcal{PN}_m be a min-based possibilistic network over the set of boolean variables $V = \{X_1, \dots, X_n\}$. Let Q be a subset of V , $e = e_1, \dots, e_l$ be an instantiation of evidence variables E (with $Q \cap E = \emptyset$) and let t be a threshold. Then $\Psi_{\mathcal{PN}_m, Q, e, t}$ over the same set of boolean variables $V = \{X_1, \dots, X_n\}$, is given by:*

$$\begin{aligned} \Psi_{\mathcal{PN}_m, Q, e, t} &= \{(\neg x_i \vee \neg u_{ij}) : \pi_{\mathcal{PN}_m}(x_i | u_{ij}) < t\} \\ &\cup \{\mathbf{e}_k : k = 1, \dots, l\} \end{aligned}$$

Clearly, this reduction is done in polynomial time (and space) with respect to the size of \mathcal{PN}_m .

Example 4. *Let us consider the possibilistic network \mathcal{PN}_m of Figure 1 over the set of variables $V = \{A, B, C, D\}$. Let $E = \{D\}$ be the set of evidence with $e = \{D = d\}$ be an instantiation of E , $Q = \{B, C\}$ be the set of query variables and $t = .5$. Then the CNF $\Psi_{\mathcal{PN}_m, \{B, C\}, d, .5}$ given by the transformation of Definition 7 is:*

$$\begin{aligned} \Psi_{\mathcal{PN}_m, \{B, C\}, d, .5} &= (c \vee b) \wedge \\ &\quad (d \vee \neg b) \wedge \\ &\quad (\neg d \vee b) \wedge \\ &\quad (\neg b \vee \neg a) \wedge \\ &\quad d \end{aligned}$$

B. Reduction from a min-based possibilistic network into a CNF

The following theorem states that π_m -**D-MAP** can be reduced to **D-SAT**.

Theorem 2. *Let \mathcal{PN}_m be a min-based possibilistic network, Q be a subset of query variables, e be an instantiation of evidence variables E and t be a real number in $(0, 1]$. Let $\Psi_{\mathcal{PN}_m, Q, e, t}$ be the CNF formula given by Definition 7. Then, π_m -**D-MAP**(\mathcal{PN}_m, Q, e, t) says "yes" if and only if **D-SAT**($\Psi_{\mathcal{PN}_m, Q, e, t}$) says "yes" where π_m -**D-MAP** is given by Definition 1 and **D-SAT** is given by Definition 2.*

Proof.

★ Assume that $\Psi_{\mathcal{PN}_m, Q, e, t}$ is satisfiable. This means that there exists an instantiation of all variables, denoted by ω^* , that satisfies all clauses of $\Psi_{\mathcal{PN}_m, Q, e, t}$ including $e = e_1, \dots, e_l$. Recall that by construction of $\Psi_{\mathcal{PN}_m, Q, e, t}$, if $(\neg x_i \vee \neg u_{ij}) \in \Psi_{\mathcal{PN}_m, Q, e, t}$ then we have $\pi_{\mathcal{PN}_m}(x_i|u_{ij}) < t$. So if ω^* satisfies all clauses in $\Psi_{\mathcal{PN}_m, Q, e, t}$ then ω^* falsifies each of the formulas in $\{(x_i \wedge u_{ij}) : (\neg x_i \vee \neg u_{ij}) \in \Psi_{\mathcal{PN}_m, Q, e, t}\}$. This means that all conditionals $\pi_{\mathcal{PN}_m}(x_i|u_{ij})$ used in chain rule for defining $\pi_{\mathcal{PN}_m}(\omega^*)$ have a possibility degree greater or equal to t . Therefore, $\pi_{\mathcal{PN}_m}(\omega^*) \geq t$.

Denoting now $q = \omega^*[Q]$ the instantiation of the variables Q such that $\omega^* \models q$, we have $\Pi_{\mathcal{PN}_m}(q \wedge e) \geq t$ since $\pi_{\mathcal{PN}_m}(\omega^*) \geq t$, $\omega^* \models q$ and $\omega^* \models e$. Hence the answer to π_m -**D-MAP**(\mathcal{PN}_m, Q, e, t) is also "yes".

★ Assume that $\Psi_{\mathcal{PN}_m, Q, e, t}$ is unsatisfiable. Then for all instantiation of variables ω such that $\omega \models e (= e_1 \wedge \dots \wedge e_l)$, there exists at least a clause $C_i = \neg x_i \vee \neg u_{ij}$ that is falsified by ω (and hence $\omega \models x_i \wedge u_{ij}$). And by construction of $\Psi_{\mathcal{PN}_m, Q, e, t}$, we have $\pi_{\mathcal{PN}_m}(x_i|u_{ij}) < t$, so using the min-based chain rule we have $\forall \omega \models e$, $\pi_{\mathcal{PN}_m}(\omega) < t$ and therefore $\forall q \in D_Q$, $\Pi_{\mathcal{PN}_m}(q \wedge e) < t$. \square

We illustrate the above theorem and its proof with an example using a *MAP* query.

Example 5. *Let us consider the CNF formula $\Psi_{\mathcal{PN}_m, \{B, C\}, d, .5}$, of Example 4, corresponding to the *MAP* query: Is there an instantiation q of query variables $\{B, C\}$ such that $\Pi_{\mathcal{PN}_m}(q \wedge e) \geq .5$? Namely, the decision problem is π_m -**D-MAP**($\mathcal{PN}_m, \{B, C\}, d, .5$). There exist two models $\neg abcd$ and $\neg ab \neg cd$. Hence, the answer to **D-SAT**($\Psi_{\mathcal{PN}_m, Q, e, t}$) is "yes". And by using the min-based chain rule on the possibilistic network of Figure 1, we get $\pi(\neg abcd) = .6$ hence $\Pi_{\mathcal{PN}_m}(bcd) = .6$ which is higher or equal than $.5$. So the answer to π_m -**D-MAP**($\mathcal{PN}_m, \{B, C\}, d, .5$) is "yes".*

For the sake of clarity, we focused on detailing the min-based possibilistic setting reduction. Therefore, the next section only gives the definition of the reduction and the main result stating the equivalence of the result of the two decision problems given the right parameters.

VIII. FROM QUERYING PRODUCT-BASED POSSIBILISTIC NETWORKS TO WMAXSAT

In this section, we will consider that the possibility degrees in the possibilistic network are of the form $2^{-\alpha_i}$ (plus 0 and 1) where α_i is a positive integer. Having uncertainty degrees of the form $2^{-\alpha_i}$ will allow us to easily reduce \mathcal{PN}_* to **WMaxSAT** given the fact that the weights used in **WMaxSAT** are integers (it is enough to use $-\log_2(2^{-\alpha_i})$ to get positive integers). This assumption is done again for the sake of clarity but the proof can be generalized to other real numbers between 0 and 1. Note that α_i may represent a degree of surprise used in Spohn's ordinal conditional function [29].

A. Definition of a weighted CNF formula associated to a product-based possibilistic network

In the following definition, we give the weighted CNF formula associated with a *MAP* query in product-based possibilistic networks. More precisely, it takes into account the evidence $e = e_1, \dots, e_l$ of the set of variables E (of size $|E| = l$), the set of query variables Q and the threshold t to produce the associated weighted CNF formula.

Definition 8. *Let \mathcal{PN}_* be a product-based possibilistic network over the set of boolean variables $V = \{X_1, \dots, X_n\}$. Let Q be a subset of V , $e = e_1, \dots, e_l$ be an instantiation of evidence variables E (with $Q \cap E = \emptyset$) and t be a threshold. Then $\Psi_{\mathcal{PN}_*, Q, e, t}$ is defined by: $\Psi_R \cup \Psi_0 \cup \Psi_e$ where*

$$\begin{aligned} \Psi_R &= \{(\neg x_i \vee \neg u_{ij}, \alpha_i) : \pi_{\mathcal{PN}_*}(x_i|u_{ij}) = 2^{-\alpha_i}\}, \\ \Psi_0 &= \{(\neg x_i \vee \neg u_{ij}, M) : \pi_{\mathcal{PN}_*}(x_i|u_{ij}) = 0\}, \\ \Psi_e &= \{(e_k, M) : k = 1, \dots, l\}, \end{aligned} \quad (7)$$

where $M > \sum \{\alpha_i : (\neg x_i \vee \neg u_{ij}, \alpha_i) \in \Psi_R\}$.

Ψ_R represents the clauses in $\Psi_{\mathcal{PN}_*, Q, e, t}$ such that have possibility degrees of the form $2^{-\alpha_i}$. Ψ_0 represents the clauses for which the possibility degrees in \mathcal{PN}_* are 0. And Ψ_e represents the clauses added to enforce the evidence. Intuitively, the integer weight M is used for fully certain pieces of information. Besides, $\Psi_0 \wedge \Psi_e$ is of course assumed to be consistent (this reflects the very reasonable assumption that the evidence is somewhat possible).

For the following, we will also denote by $X = \sum \{\alpha_i : (\neg x_i \vee \neg u_{ij}, \alpha_i) \in \Psi_R\}$ the sum of weights in Ψ_R .

B. Reduction from a product-based possibilistic network to a weighted CNF formula

Theorem 3 provides the reduction from the decision problem π_m -**D-MAP**(\mathcal{PN}_*, Q, e, t) into **D-WMaxSAT**($\Psi_{\mathcal{PN}_*, Q, e, t}, k$). We will denote by Z the number of possibility degrees, $\pi_{\mathcal{PN}_*}(x_i|u_{ij})$ in \mathcal{PN}_* that are equal to 0 (namely, Z is the number of clauses in Ψ_0).

The input k is let to $X + \log_2 t + M * (Z + |E|)$ while $\Psi_{\mathcal{PN}_*, Q, e, t}$ is the weighted CNF formula given associated to \mathcal{PN}_* given by Definition 8 (we also assume for only sake of simplicity that t is of the form $2^{-\alpha}$ with α an integer). More formally:

Theorem 3. Let \mathcal{PN}_* be a product-based possibilistic network. Let Q be a subset of V , e be an instantiation of variables E and t be a threshold. Let $\Psi_{\mathcal{PN}_*, Q, e, t}$ be the CNF formula given by Definition 8. Then, $\pi_*\text{-D-MAP}(\mathcal{PN}_*, Q, e, t)$ answers "yes" if and only if $\text{D-WMaxSAT}(\Psi_{\mathcal{PN}_*, Q, e, t}, X + \log_2 t + M * (Z + |E|))$ answers "yes" where $\pi_*\text{-D-MAP}$ is given by Definition 1 and D-WMaxSAT is given by Definition 4.

IX. CONCLUSIONS

As stressed out in the motivations, inference in probabilistic models is a hard task in the general case. Indeed, computing MAP queries in Bayesian networks is NP^{PP} -complete [14], [26]. This paper provided crucial complexity results for possibilistic networks where MAP inference queries are shown to be NP -complete. Especially, these results are valid in both min-based and product-based possibilistic networks.

A future work concerns the computational complexity analysis of MAP queries in interval-based possibilistic networks. We believe that our results on MAP queries will still hold in the interval-based possibilistic setting. Since in interval-based possibilistic logic the complexity of conditioning is the same as the complexity of conditioning a standard possibilistic knowledge base. Among other future works, we also argue that the nice complexity results of possibilistic networks shown in this paper can really benefit for inference in probabilistic credal networks where these latter can be approximated by possibilistic networks by means of imprecise probability-possibility transformations [4], [25].

X. ACKNOWLEDGMENTS

This work benefited from the support of the project AniAge MSCA-RISE - Marie Skodowska-Curie Research and Innovation Staff Exchange (RISE).

REFERENCES

- [1] Mohammad Mahdi Abaei, Rouzbeh Abbassi, Vikram Garaniya, Shuhong Chai, and Faisal Khan. Reliability assessment of marine floating structures using bayesian network. *Applied Ocean Research*, 76:51–60, 2018.
- [2] Nahla Ben Amor, Didier Dubois, H ela Gouider, and Henri Prade. Preference modeling with possibilistic networks and symbolic weights: A theoretical study. In *ECAI 2016 - , The Hague, The Netherlands*, pages 1203–1211, 2016.
- [3] Salem Benferhat, Am elie Levray, and Karim Tabia. Probability-possibility transformations: Application to credal networks. In *SUM 2015, Qu ebec City, QC, Canada, September 16-18, 2015. Proceedings*, pages 203–219, 2015.
- [4] Salem Benferhat, Am elie Levray, and Karim Tabia. Approximating map inference in credal networks using probability-possibility transformations. In *Proceedings of the 29th ICTAI, Boston, MA, USA, 2017*.
- [5] Salem Benferhat and Karim Tabia. Inference in possibilistic network classifiers under uncertain observations. *Ann. Math. Artif. Intell.*, 64(2-3):269–309, 2012.
- [6] Christian Borgelt, Jorg Gebhardt, and Rudolf R. Kruse. Graphical models. In *Proceedings of International School for the Synthesis of Expert Knowledge*, pages 51–68. Wiley, 2002.
- [7] Christian Borgelt and Rudolf Kruse. *Graphical models - methods for data analysis and mining*. Wiley, 2002.
- [8] Marcos L.P. Bueno, Arjen Hommersom, Peter J.F. Lucas, Martijn Lappenschaar, and Joost G.E. Janzing. Understanding disease processes by partitioned dynamic bayesian networks. *J. of Biomedical Informatics*, pages 283 – 297, 2016.
- [9] Sofie De Clercq, Steven Schockaert, Ann Now e, and Martine De Cock. Modelling incomplete information in boolean games using possibilistic logic. *Int. J. Approx. Reasoning*, 93:1–23, 2018.
- [10] Gregory F. Cooper. The computational complexity of probabilistic inference using bayesian belief networks. *Artif. Intell.*, 42(2-3):393–405, 1990.
- [11] Adnan Darwiche. *Modeling and Reasoning with Bayesian Networks*. Cambridge University Press, 2009.
- [12] Adnan Darwiche and James D. Park. Complexity results and approximation strategies for MAP explanations. *CoRR*, abs/1107.0024, 2011.
- [13] Cassio P. De Campos. New complexity results for map in bayesian networks. In Toby Walsh, editor, *IJCAI*, pages 2100–2106. IJCAI/AAAI, 2011.
- [14] Cassio P. De Campos and F abio G. Cozman. The inferential complexity of bayesian and credal networks. In *Proceedings of the 19th IJCAI, Edinburgh, Scotland, UK, July 30 - August 5*, pages 1313–1318. Professional Book Center, 2005.
- [15] Gert De Cooman. Possibility theory part i: Measure-and integral-theoretics groundwork; part ii: Conditional possibility; part iii: Possibilistic independence. *International Journal of General Systems*, 25:291–371, 1997.
- [16] Didier Dubois, Giovanni Fusco, Henri Prade, and Andrea G. B. Tettamanzi. Uncertain logical gates in possibilistic networks: Theory and application to human geography. *Int. J. Approx. Reasoning*, 82:101–118, 2017.
- [17] Didier Dubois and Henri Prade. Inference in possibilistic hypergraphs. In *Proceedings of the 3rd International Conference on Information Processing and Management of Uncertainty in Knowledge-Based Systems: Uncertainty in Knowledge Bases, IPMU ’90*, pages 250–259, London, UK, UK, 1991. Springer-Verlag.
- [18] Didier Dubois and Henri Prade. *Possibility Theory: Qualitative and Quantitative Aspects*, pages 169–226. Springer Netherlands, Dordrecht, 1998.
- [19] Didier Dubois and Henri Prade. Possibilistic logic - an overview. In J org H. Siekmann, editor, *Computational Logic*, volume 9 of *Handbook of the History of Logic*, pages 283–342. Elsevier, 2014.
- [20] Laurent Garcia and R egis Sabbadin. Complexity results and algorithms for possibilistic influence diagrams. *Artif. Intell.*, 172(8-9):1018–1044, 2008.
- [21] Ellen Hisdal. Conditional possibilities independence and non interaction. *Fuzzy Sets and Systems*, pages 283–297, 1978.
- [22] Paul J. Krause. Learning probabilistic networks. *Knowledge Eng. Review*, 13(4):321–351, 1999.
- [23] Dario Malchiodi and Andrea G. B. Tettamanzi. Predicting the possibilistic score of owl axioms through modified support vector clustering. 2018 (To appear).
- [24] Simone Marini, Emanuele Trifoglio, Nicola Barbarini, Francesco Sambo, Barbara Di Camillo, Alberto Malovini, Marco Manfrini, Claudio Cobelli, and Riccardo Bellazzi. A dynamic bayesian network model for long-term simulation of clinical complications in type 1 diabetes. *J. of Biomedical Informatics*, 57:369 – 376, 2015.
- [25] Marie-H el ene Masson and Thierry Denooux. Inferring a possibility distribution from empirical data. *Fuzzy Sets and Systems*, 157(3):319–340, 2006.
- [26] Denis D. Mau a, Cassio P. de Campos, and F abio G. Cozman. The complexity of MAP inference in bayesian networks specified through logical languages. In Qiang Yang and Michael Wooldridge, editors, *Proceedings of the Twenty-Fourth IJCAI, Buenos Aires, Argentina, July 25-31*, pages 889–895. AAAI Press, 2015.
- [27] Judea Pearl. *Probabilistic reasoning in intelligent systems - networks of plausible inference*. Morgan Kaufmann, 1989.
- [28] J er emy Roos, G erald Gavin, and St ephane Bonnevey. A dynamic bayesian network approach to forecast short-term urban rail passenger flows with incomplete data. *Transportation Research Procedia*, 26:53 – 61, 2017. Emerging technologies and models for transport and mobility.
- [29] Wolfgang Spohn. Ordinal conditional functions. a dynamic theory of epistemic states. In W. L. Harper and B. Skyrms, editors, *Causation in Decision, Belief Change, and Statistics, vol. II*. Kluwer Academic Publishers, 1988.
- [30] Andrea G. B. Tettamanzi, Catherine Faron-Zucker, and Fabien Gandon. Possibilistic testing of OWL axioms against RDF data. *Int. J. Approx. Reasoning*, 91:114–130, 2017.